

Constraint Satisfaction Problems

Sections 3.7 and 4.4, Chapter 5 of AIMA2e

Z. Duric

GMU

CS 480

2

Outline

- ◇ CSP examples
- ◇ Backtracking search for CSPs
- ◇ Problem structure and problem decomposition
- ◇ Local search for CSPs

Z. Duric

GMU

Constraint satisfaction problems (CSPs)

Standard search problem:

state is a “black box”—any old data structure
that supports goal test, eval, successor

CSP:

state is defined by *variables* X_i with *values* from *domain* D_i

goal test is a set of *constraints* specifying
allowable combinations of values for subsets of variables

Simple example of a *formal representation language*

Allows useful *general-purpose* algorithms with more power
than standard search algorithms

Z. Duric

GMU

CS 480

4

Example: Map-Coloring

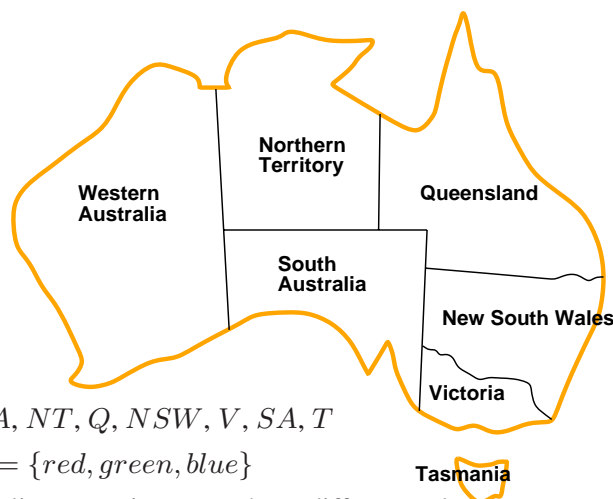

Variables WA, NT, Q, NSW, V, SA, T

Domains $D_i = \{red, green, blue\}$

Constraints: adjacent regions must have different colors

e.g., $WA \neq NT$ (if the language allows this), or

$(WA, NT) \in \{(red, green), (red, blue), (green, red), (green, blue), \dots\}$

Z. Duric

GMU

Example: Map-Coloring contd.

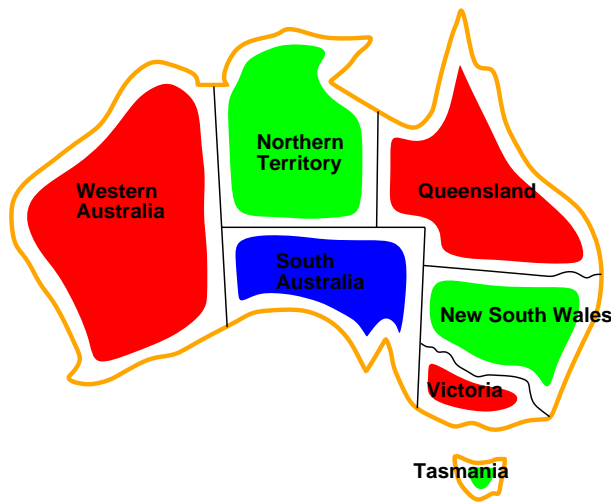

Solutions are assignments satisfying all constraints, e.g.,

$\{WA = red, NT = green, Q = red, NSW = green, V = red, SA = blue, T = green\}$

Z. Duric

GMU

CS 480

6

Constraint graph

Binary CSP: each constraint relates at most two variables

Constraint graph: nodes are variables, arcs show constraints

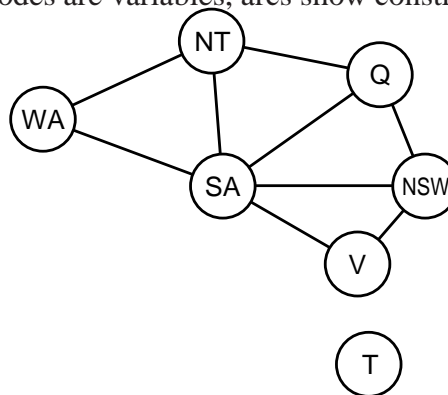

General-purpose CSP algorithms use the graph structure to speed up search. E.g., Tasmania is an independent subproblem!

Z. Duric

GMU

Varieties of CSPs

Discrete variables

finite domains; size $d \Rightarrow O(d^n)$ complete assignments

◇ e.g., Boolean CSPs, incl. Boolean satisfiability

(NP-complete)

infinite domains (integers, strings, etc.)

◇ e.g., job scheduling, variables are start/end days for each

job

◇ need a **constraint language**, e.g.,

$StartJob_1 + 5 \leq StartJob_3$

◇ **linear** constraints solvable, **nonlinear** undecidable

Continuous variables

◇ e.g., start/end times for Hubble Telescope observations

◇ linear constraints solvable in poly time by LP methods

Varieties of constraints

Unary constraints involve a single variable,

e.g., $SA \neq green$

Binary constraints involve pairs of variables,

e.g., $SA \neq WA$

Higher-order constraints involve 3 or more variables,

e.g., cryptarithmic column constraints

Preferences (soft constraints), e.g., *red* is better than *green*

often representable by a cost for each variable assignment

→ constrained optimization problems

Example: Cryptarithmic

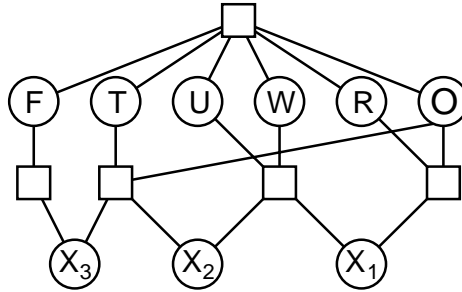
$$\begin{array}{r} T W O \\ + T W O \\ \hline F O U R \end{array}$$

Variables: $F T U W R O X_1 X_2 X_3$

Domains: $\{0, 1, 2, 3, 4, 5, 6, 7, 8, 9\}$

Constraints

$alldiff(F, T, U, W, R, O)$

$O + O = R + 10 \cdot X_1$, etc.

Real-world CSPs

Assignment problems

e.g., who teaches what class

Timetabling problems

e.g., which class is offered when and where?

Hardware configuration

Spreadsheets

Transportation scheduling

Factory scheduling

Floorplanning

Notice that many real-world problems involve real-valued variables

Standard search formulation (incremental)

Let's start with the straightforward, dumb approach, then fix it

States are defined by the values assigned so far

- ◇ **Initial state:** the empty assignment, \emptyset
- ◇ **Successor function:** assign a value to an unassigned variable that does not conflict with current assignment.
⇒ fail if no legal assignments (not fixable!)
- ◇ **Goal test:** the current assignment is complete

- 1) This is the same for all CSPs!
- 2) Every solution appears at depth n with n variables
⇒ use depth-first search
- 3) Path is irrelevant, so can also use complete-state formulation
- 4) $b = (n - \ell)d$ at depth ℓ , hence $n!d^n$ leaves!!!!

Backtracking search

Variable assignments are **commutative**, i.e.,

$[WA = red \text{ then } NT = green]$ same as $[NT = green \text{ then } WA = red]$

Only need to consider assignments to a single variable at each node

⇒ $b = d$ and there are d^n leaves

Depth-first search for CSPs with single-variable assignments is called **backtracking** search

Backtracking search is the basic uninformed algorithm for CSPs

Can solve n -queens for $n \approx 25$

Backtracking search

```
function BACKTRACKING-SEARCH(csp) returns solution/failure
  return RECURSIVE-BACKTRACKING([], csp)

function RECURSIVE-BACKTRACKING(assigned, csp) returns solution/failure
  if assigned is complete then return assigned
  var ← SELECT-UNASSIGNED-VARIABLE(VARIABLES[csp], assigned, csp)
  for each value in ORDER-DOMAIN-VALUES(var, assigned, csp) do
    if value is consistent with assigned according to CONSTRAINTS[csp] then
      result ← RECURSIVE-BACKTRACKING([var = value | assigned], csp)
      if result ≠ failure then return result
  end
  return failure
```

Backtracking example



Backtracking example

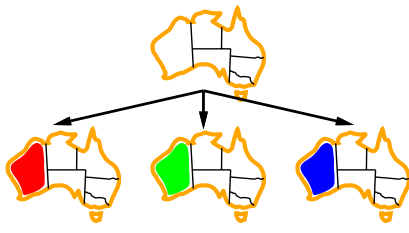

Z. Duric

GMU

CS 480

16

Backtracking example

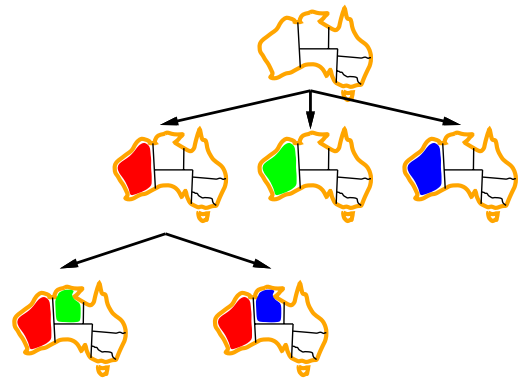

Z. Duric

GMU

Backtracking example

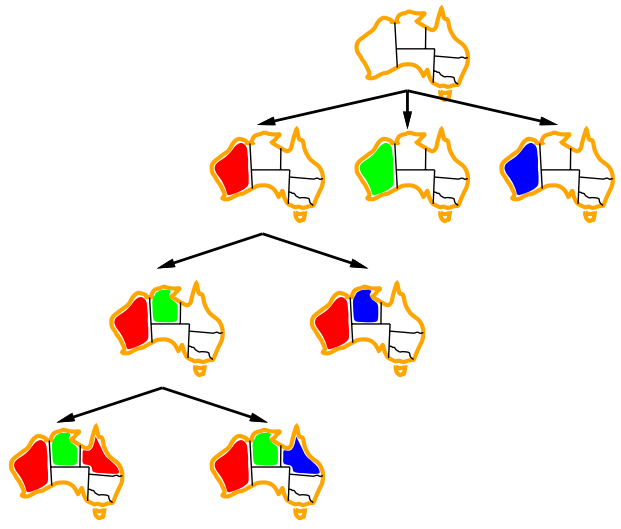

Improving backtracking efficiency

General-purpose methods can give huge gains in speed:

1. Which variable should be assigned next?
2. In what order should its values be tried?
3. Can we detect inevitable failure early?
4. Can we take advantage of problem structure?

Most constrained variable

Most constrained variable:

choose the variable with the fewest legal values

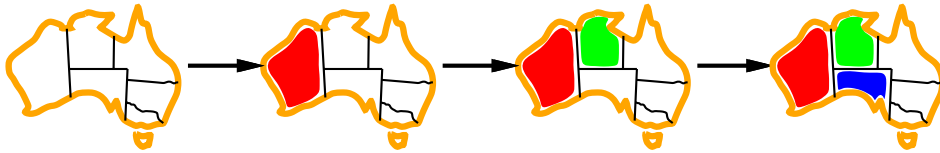

Z. Duric

GMU

CS 480

20

Most constraining variable

Tie-breaker among most constrained variables

Most constraining variable:

choose the variable with the most constraints on remaining variables

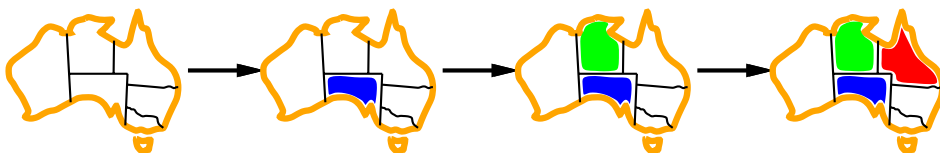

Z. Duric

GMU

Least constraining value

Given a variable, choose the least constraining value:
the one that rules out the fewest values in the remaining variables

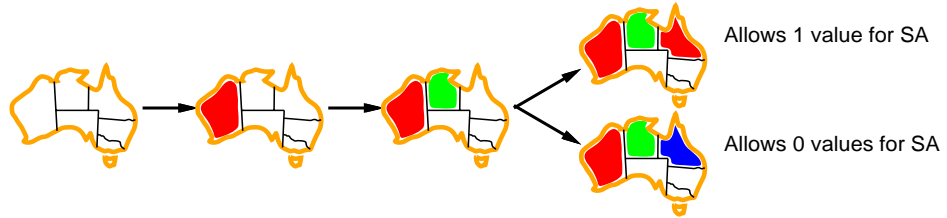

Combining these heuristics makes 1000 queens feasible

Z. Duric

GMU

CS 480

22

Forward checking

Idea: Keep track of remaining legal values for unassigned variables
Terminate search when any variable has no legal values



Z. Duric

GMU

Forward checking

Idea: Keep track of remaining legal values for unassigned variables
 Terminate search when any variable has no legal values

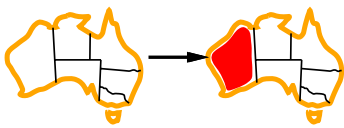

Forward checking

Idea: Keep track of remaining legal values for unassigned variables
 Terminate search when any variable has no legal values

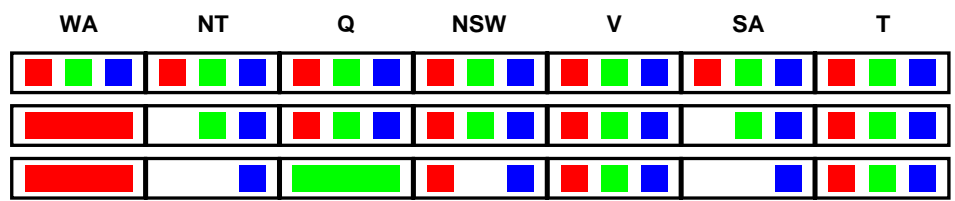

Arc consistency

Simplest form of propagation makes each arc **consistent**

$X \rightarrow Y$ is consistent iff

for *every* value x of X there is *some* allowed y

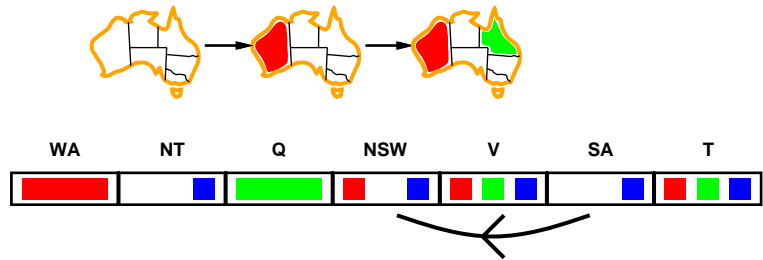

Arc consistency

Simplest form of propagation makes each arc **consistent**

$X \rightarrow Y$ is consistent iff

for *every* value x of X there is *some* allowed y

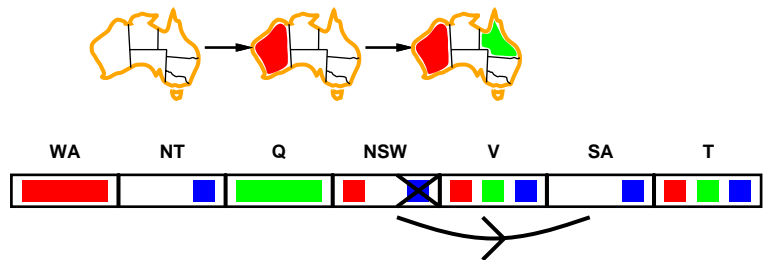

Arc consistency

Simplest form of propagation makes each arc **consistent**

$X \rightarrow Y$ is consistent iff

for *every* value x of X there is *some* allowed y

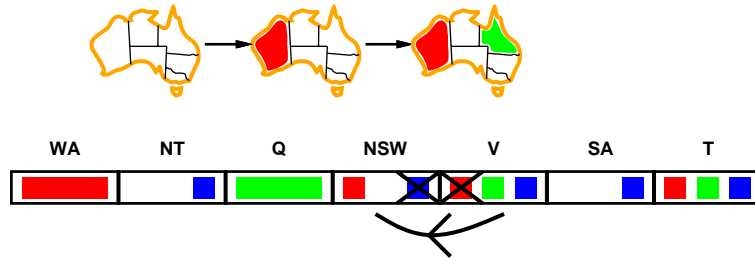

If X loses a value, neighbors of X need to be rechecked

Arc consistency

Simplest form of propagation makes each arc **consistent**

$X \rightarrow Y$ is consistent iff

for *every* value x of X there is *some* allowed y

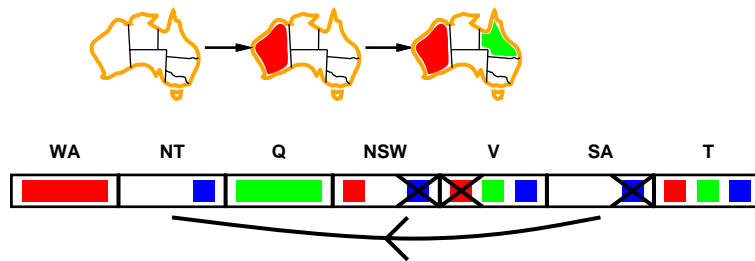

If X loses a value, neighbors of X need to be rechecked

Arc consistency detects failure earlier than forward checking

Can be run as a preprocessor or after each assignment

Arc consistency algorithm

```
function AC-3(csp) returns the CSP, possibly with reduced domains
inputs: csp, a binary CSP with variables  $\{X_1, X_2, \dots, X_n\}$ 
local variables: queue, a queue of arcs, initially all the arcs in csp

while queue is not empty do
   $(X_i, X_j) \leftarrow \text{REMOVE-FIRST}(\textit{queue})$ 
  if REMOVE-INCONSISTENT-VALUES( $X_i, X_j$ ) then
    for each  $X_k$  in NEIGHBORS[ $X_i$ ] do
      add  $(X_k, X_i)$  to queue

function REMOVE-INCONSISTENT-VALUES( $X_i, X_j$ ) returns true iff we remove a value
  removed  $\leftarrow$  false
  for each  $x$  in DOMAIN[ $X_i$ ] do
    if no value  $y$  in DOMAIN[ $X_j$ ] allows  $(x,y)$  to satisfy the constraint between  $X_i$  and  $X_j$ 
    then delete  $x$  from DOMAIN[ $X_i$ ]; removed  $\leftarrow$  true
  return removed
```

$O(n^2 d^3)$, can be reduced to $O(n^2 d^2)$
but cannot detect all failures in poly time!

Z. Duric

GMU

CS 480

32

Problem structure

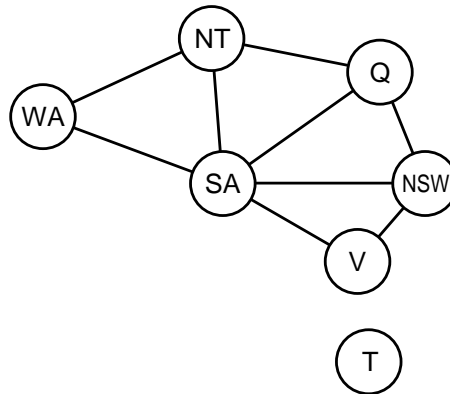

Tasmania and mainland are **independent subproblems**

Identifiable as **connected components** of constraint graph

Z. Duric

GMU

Problem structure contd.

Suppose each subproblem has c variables out of n total

Worst-case solution cost is $n/c \cdot d^c$, *linear* in n

E.g., $n = 80$, $d = 2$, $c = 20$

$2^{80} = 4$ billion years at 10 million nodes/sec

$4 \cdot 2^{20} = 0.4$ seconds at 10 million nodes/sec

Tree-structured CSPs

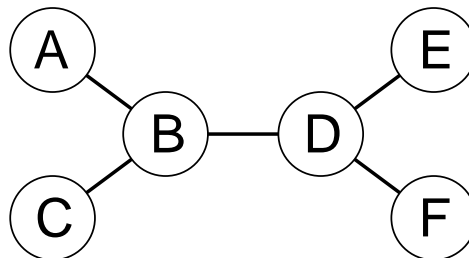

Theorem: if the constraint graph has no loops, the CSP can be solved in $O(n d^2)$ time

Compare to general CSPs, where worst-case time is $O(d^n)$

This property also applies to logical and probabilistic reasoning:
an important example of the relation between syntactic restrictions
and the complexity of reasoning.

Algorithm for tree-structured CSPs

1. Choose a variable as root, order variables from root to leaves such that every node's parent precedes it in the ordering

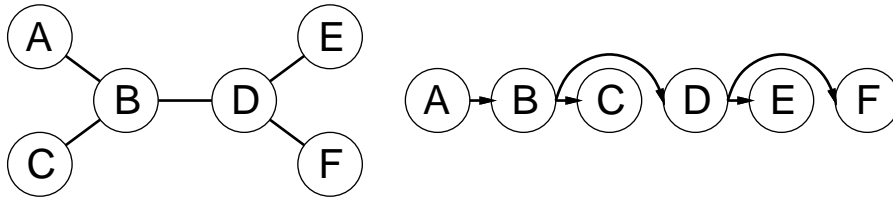

2. For j from n down to 2, apply REMOVEINCONSISTENT($Parent(X_j), X_j$)
3. For j from 1 to n , assign X_j consistently with $Parent(X_j)$

Z. Duric

GMU

CS 480

36

Nearly tree-structured CSPs

Conditioning: instantiate a variable, prune its neighbors' domains

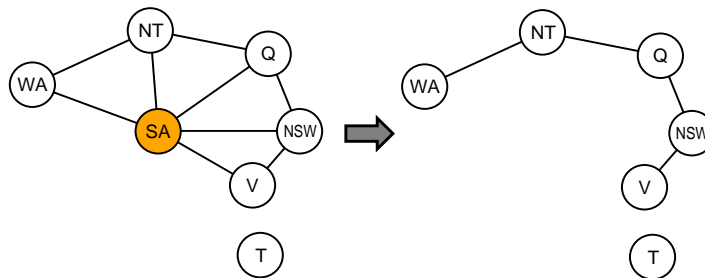

Cutset conditioning: instantiate (in all ways) a set of variables such that the remaining constraint graph is a tree

Cutset size $c \Rightarrow$ runtime $O(d^c \cdot (n - c)d^2)$, very fast for small c

Z. Duric

GMU

Iterative algorithms for CSPs

Hill-climbing, simulated annealing typically work with “complete” states, i.e., all variables assigned

To apply to CSPs:

- allow states with unsatisfied constraints
- operators *reassign* variable values

Variable selection: randomly select any conflicted variable

Value selection by *min-conflicts* heuristic:

- choose value that violates the fewest constraints
- i.e., hillclimb with $h(n)$ = total number of violated constraints

Example: 4-Queens

States: 4 queens in 4 columns ($4^4 = 256$ states)

Operators: move queen in column

Goal test: no attacks

Evaluation: $h(n)$ = number of attacks

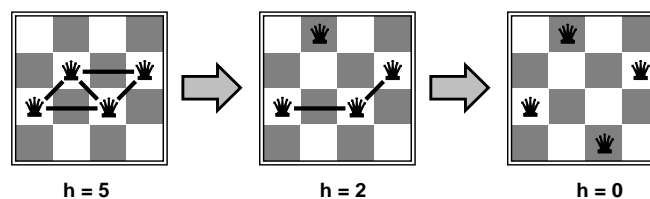

Performance of min-conflicts

Given random initial state, can solve n -queens in almost constant time for arbitrary n with high probability (e.g., $n = 10,000,000$)

The same appears to be true for any randomly-generated CSP **except** in a narrow range of the ratio

$$R = \frac{\text{number of constraints}}{\text{number of variables}}$$

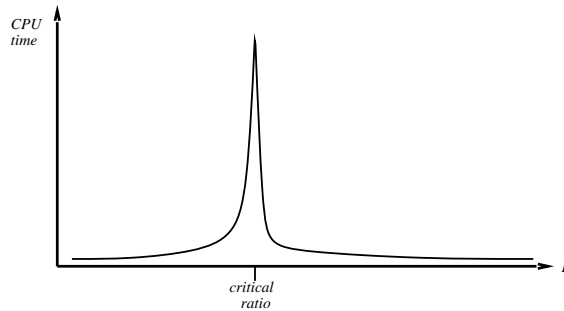

Z. Duric

GMU

CS 480

40

Summary

CSPs are a special kind of problem:

- states defined by values of a fixed set of variables
- goal test defined by *constraints* on variable values

Backtracking = depth-first search with one variable assigned per node

Variable ordering and value selection heuristics help significantly

Forward checking prevents assignments that guarantee later failure

Constraint propagation (e.g., arc consistency) does additional work to constrain values and detect inconsistencies

The CSP representation allows analysis of problem structure

Tree-structured CSPs can be solved in linear time

Iterative min-conflicts is usually effective in practice

Z. Duric

GMU

Example: 4-Queens as a CSP

Assume one queen in each column. Which row does each one go in?

Variables Q_1, Q_2, Q_3, Q_4

Domains $D_i = \{1, 2, 3, 4\}$

Constraints

$Q_i \neq Q_j$ (cannot be in same row)

$|Q_i - Q_j| \neq |i - j|$ (or same diagonal)

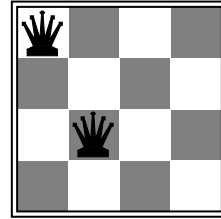

$Q_1 = 1 \quad Q_2 = 3$

Translate each constraint into set of allowable values for its variables

E.g., values for (Q_1, Q_2) are $(1, 3) (1, 4) (2, 4) (3, 1) (4, 1) (4, 2)$